

FSI VACUUM HEADS

Frequency Scanning Interferometry (FSI) measurement system built into an interface between atmospheric and vacuum and/or cryogenic environments.

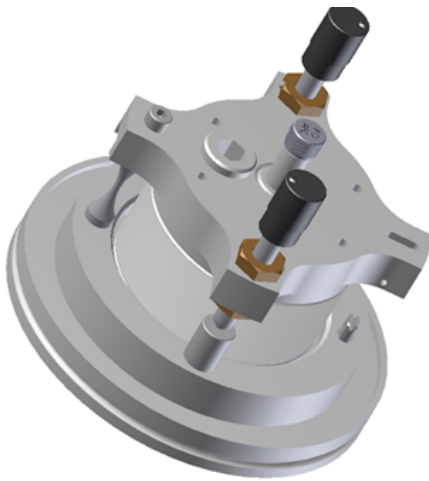

CERN metrology group has developed the FSI Vacuum Heads, in particular for the HL-LHC project, to monitor changes of the position of crab cavities as they are put under vacuum and cryogenic conditions.

The device is essentially an FSI measurement system built into an interface between atmospheric conditions and a vacuum and/or cryogenic environment, enabling FSI (absolute) measurement with high precision. Conventionally, such measurements would be done through a strong glass window.

By using a device such as the FSI head we increase the precision because refraction issues (from light passing through glass windows at vacuum interface) are removed. The laser beam for FSI is provided by fibre into the device.

AREA OF EXPERTISE

- Metrology

CONTACT PERSON

amy.bilton@cern.ch

Find out more at:
cern.ch/knowledgetransfer

FEATURES

- Compatible with absolute and relative interferometric systems.
- Uncertainty : typical 10-15 μ m (depending of fiducialisation on method of the head).
- Measurement distance in vacuum: 0.2m – several meters (internal construction might be easily adopted to user need).
- Fibre length – up to several hundreds meters (depends on interferometric system limitation).

APPLICATIONS

- Contactless measurement of different temperature objects allowing for heat conduction effects minimizing.
- Very high precision alignment for aerospace applications.

